



Quick Start Guide

ELITE-REMOTE



Quick Start Guide

Thank you for purchasing the ELITE-REMOTE – Bluetooth iPad teleprompter remote. Please follow these simple instructions to get started.

Downloading Compatible Apps

1. Go to the App Store on your tablet



2. Locate the search bar at the top right corner and key in the name of one of our compatible apps.



Teleprompter Premium



Teleprompt+ 3

3. Select the app and install it.

Inserting battery into ELITE-REMOTE

1. Remove the cover on the back of the remote
2. Insert 2 AAA batteries into the battery compartment
3. Re-install the battery cover

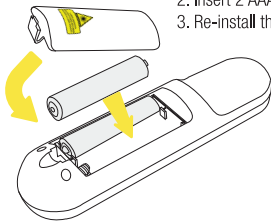

Syncing ELITE-REMOTE to your iPad

1. Go to the "Settings" app on your iPad
2. Select the Bluetooth tab on the left side and confirm the Bluetooth option is on (switch will toggle green).
3. Turn on the remote by inserting 2 AAA batteries into the battery compartment. A red light should blink momentarily on the front side of the remote.

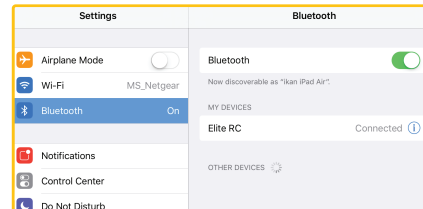

4. Press and hold the "Rewind & Forward" button for 3 seconds to sync the remote. A blue light should blink momentarily on the front side of the remote.
5. The words "Elite RC" should appear on your iPad. Select it.
6. Once connection between the iPad and the remote has been established, the status message next to "Elite RC" should change to Connected.

Re-establishing connection with your iPad

Once you sync your iPad and ELITE-REMOTE, your iPad will always remember the ELITE-REMOTE. To re-establish connection, simply turn on the remote, press any button, and wait a few seconds. The remote will automatically re-establish connection with your iPad.

Troubleshooting

If you have any issues with the ELITE-REMOTE, please call us at 1.713.272.8822 Monday through Friday 9:00 am to 6:00 pm CST. Or you can email us at support@ikancorp.com.

© Kan International 2022. All Rights Reserved.



Controlling your iPad with ELITE-REMOTE

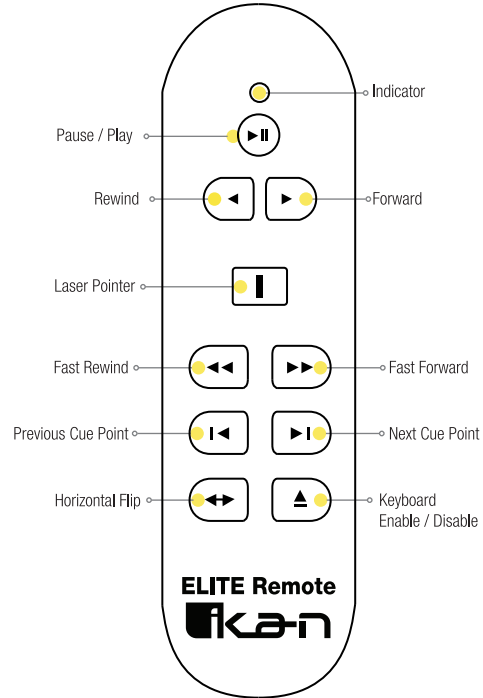

PrompterPro4 Control

